



## SunSpec Modbus

**Rev 3.3**

This document provides a method for reading inverter information(voltage, current, power, etc.) via the standard Modbus protocol.

# Table of Contents

<b>1. Hardware description .....</b>	<b>3</b>
<b>2. Software configuration .....</b>	<b>4</b>
<b>2.1 Open ECU local page .....</b>	<b>4</b>
<b>2.2 Configure SunSpec Modbus function .....</b>	<b>4</b>
<b>2.3 Host serial port configuration .....</b>	<b>4</b>
<b>3. SunSpec (PICS) - Allocation Tables .....</b>	<b>6</b>

## 0.Check support

Only ECUs that meet the conditions are supported.

	ID rules	Version	Support
ECU-R	2160XXXXXXXXX	1.3.7 or above	✓
	2162XXXXXXXXX	2.0.2 or above	✓
ECU-B	2163XXXXXXXXX	ALL versions	✗
ECU-C	215XXXXXXXXXX	C1.1.3 or above	✓

# 1. Hardware description

We support two modbus modes: Modbus-RTU and Modbus-TCP  
RTU needs 485 bus connection, TCP needs network connection.

ECU-R's RS485 communication interface is between power hole and RJ45 network port.  
It can be connected by Serial line.

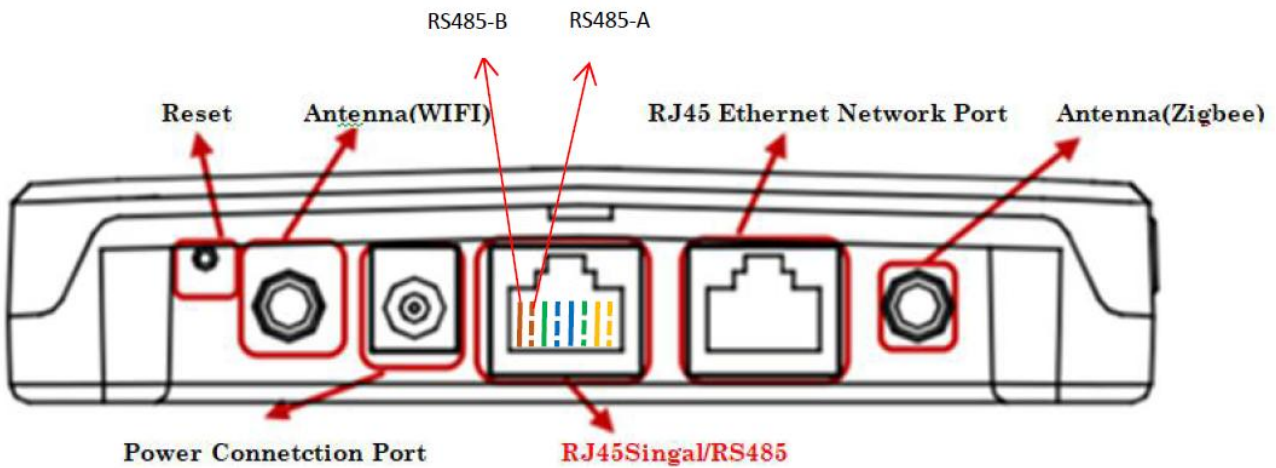

ECU-C's RS485 interface is on the surface. It can be connected by Serial line.

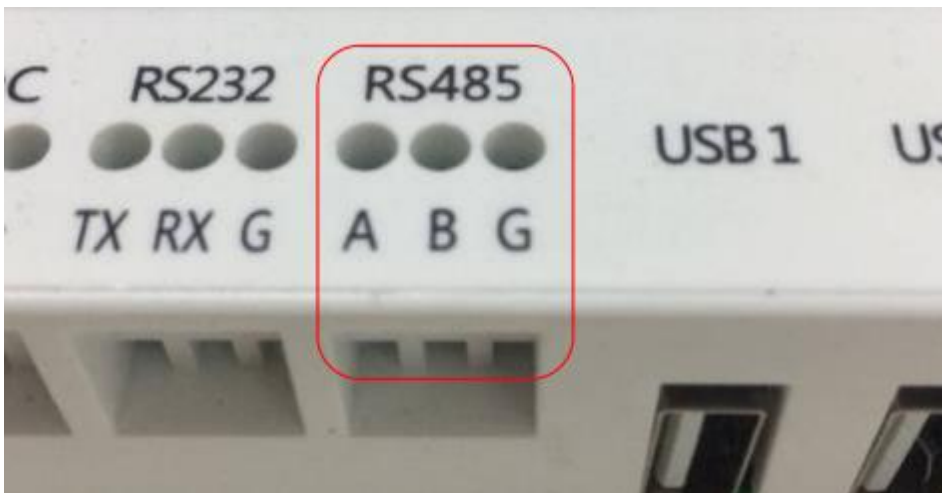

## 2. Software configuration

### 2.1 Config switch, baud and address

Open “EManager” -> ECU APP -> Workspace -> Modbus Configuration

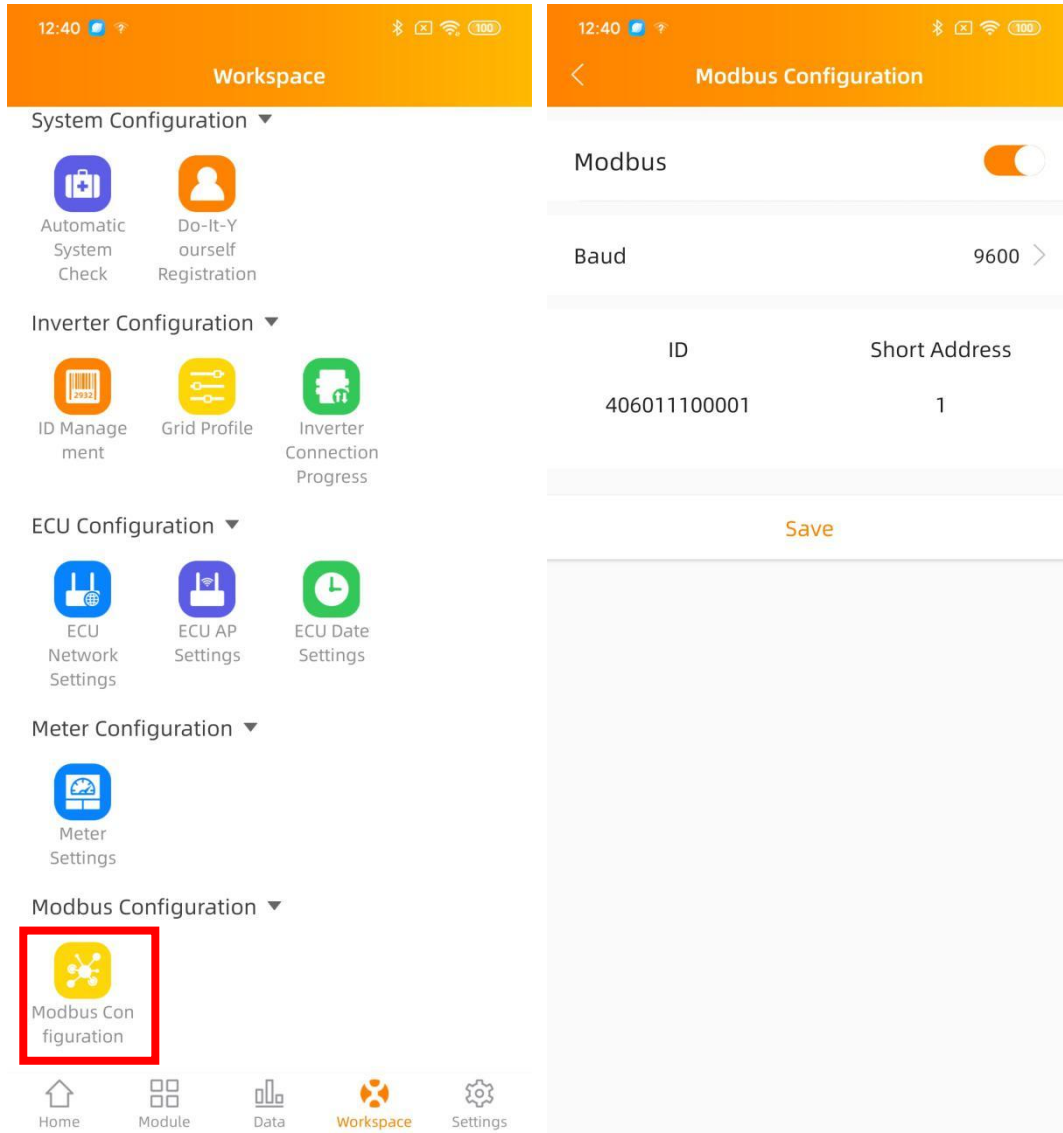

Figure 1

### 2.2 Configure SunSpec Modbus function

Select “On” in Switch menu to turn on the SunSpec Modbus function. Select a baud rate in the second menu. Configure Inverters’ address in the address text box. Finally, click **Save** to finish configuration.

### 2.3 Host serial port configuration

The host’s RS485 port must be configured to the same baud rate, 8 data bits, 1 stop bit, none parity bit, but ignore baud rate with TCP-modbus.

## 2. Software configuration

RTU: Must be connected to RS485

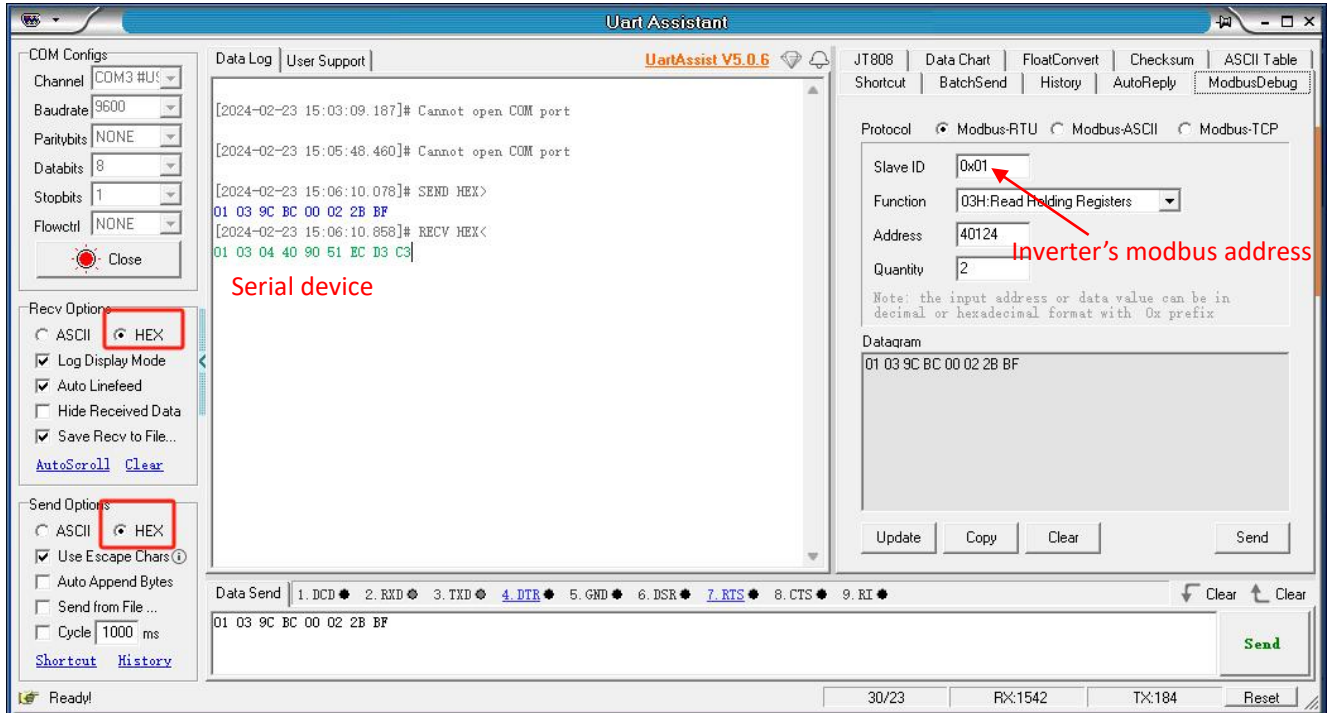

TCP: No need to connect RS485

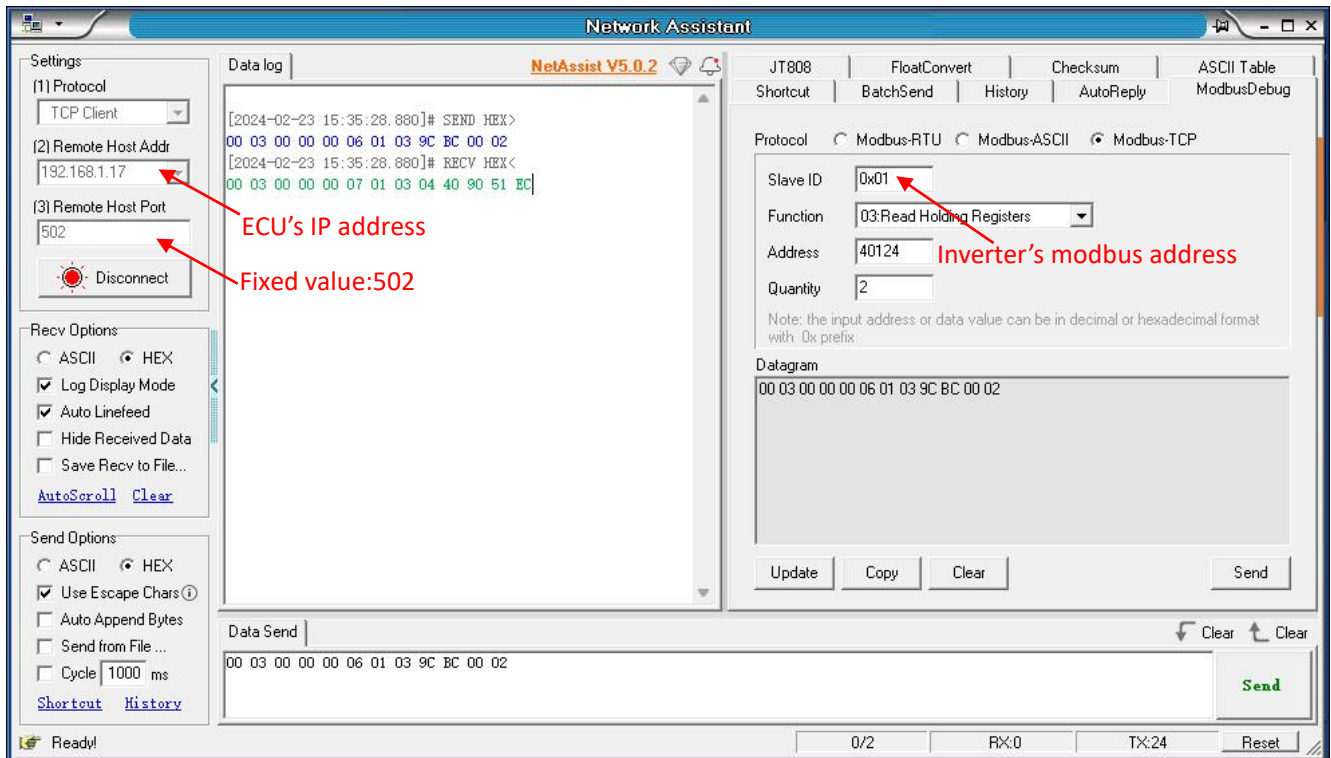

**NOTE:** This tool is for debugging only, other similar tools can also be used.

## 3. SunSpec (PICS) - Allocation Tables

### Basic information table:

Address	Point	Field Type	Address Offset	Block Offset	Size	Name	Label	Value	Type	R/W	Mandatory I/O	Description
40002	ID	Header	0		1	ID	Common	1	uint16	R	M	All SunSpec compliant devices must include this as the first model
40003	L	Header	1		1	L		66	uint16	R	M	Model Length
40004	Manufacturer (Mn)	Fixed Block	2	0	16	Mn	Manufacturer	APsystems	string	R	M	Well known value registered with SunSpec for compliance
40020	Model (Md)	Fixed Block	18	16	16	Md	Model	YC600	string	R	M	Manufacturer specific value (32 chars)
40036	Options (Opt)	Fixed Block	34	32	8	Opt	Options	unimplemented	string	R	O	Manufacturer specific value (16 chars)
40044	Version (Vr)	Fixed Block	42	40	8	Vr	Version	V0	string	R	O	Manufacturer specific value (16 chars)
40052	Serial Number (SN)	Fixed Block	50	48	16	SN	Serial Number	409000064675	string	R	M	Manufacturer specific value (32 chars)
40068	Device Address (DA)	Fixed Block	66	64	1	DA	Device Address	1	uint16	RW	O	Modbus device address
40069	Pad	Fixed Block	67	65	1	Pad			pad	R	O	Force even alignment

eg. (if Address=1)

RS485 send: 01 03 9C 44 00 05 EB 8C

Will recv: 01 03 0A 41 50 73 79 73 74 65 6D 73 00 35 7B

01:device address(defined in Settings)

03:fixed value,means Read Holding Register

9C 44:Convert to decimal is 40004,so this command is used to read Manufacturer(string)

00 05:How many registers are read

EB 8C:CRC check (CRC-16/MODBUS x16+x15+x2+1)

0A:length of response content,this is 10

41 50 73 79 73 74 65 6D 73 00:response content,10 bytes,Corresponding ascii,get "APsystems"

35 7B:CRC check (CRC-16/MODBUS x16+x15+x2+1)

Note:Modbus-TCP don't need CRC check, but need 6 bytes protocol header

TCP send: 00 01 00 00 00 06 01 03 9C 44 00 05

Will recv: 00 01 00 00 00 0D 01 03 0A 41 50 73 79 73 74 65 6D 73 00

"00 01 00 00" is arbitrary.

"00 06" is the length of data

# for single phase inverter monitoring table:

Address	Point	Field Type	Applicable Point	Address Offset	Block Offset	Size	Name	Label	Value	Type	Units	SF	R/W	Mandatory N/O	Description
40070	ID	Header		0		1	ID	Inverter (Single Phase)	101	uint16			R	M	Include this model for s
40071	L	Header		1		1	L		50	uint16			R	M	Inverter monitoring Model Length
40072	Amps (A)	Fixed Block		2	0	1	A	Amps	supported	uint16	A	A_SF	R	M	AC Current
40073	Amps PhaseA (Apha)	Fixed Block		3	1	1	AphA	Amps PhaseA	supported	uint16	A	A_SF	R	M	Phase A Current
40074	Amps PhaseB (AphB)	Fixed Block		4	2	1	AphB	Amps PhaseB	unimplemented	uint16	A	A_SF	R	O	Phase B Current
40075	Amps PhaseC (AphC)	Fixed Block		5	3	1	AphC	Amps PhaseC	unimplemented	uint16	A	A_SF	R	O	Phase C Current
40076	A_SF	Fixed Block		6	4	1	A_SF		-2	sunssf			R	M	
40077	Phase Voltage AB (PPVphAB)	Fixed Block		7	5	1	PPVphAB	Phase Voltage AB	unimplemented	uint16	V	V_SF	R	O	Phase Voltage AB
40078	Phase Voltage BC (PPVphBC)	Fixed Block		8	6	1	PPVphBC	Phase Voltage BC	unimplemented	uint16	V	V_SF	R	O	Phase Voltage BC
40079	Phase Voltage CA (PPVphCA)	Fixed Block		9	7	1	PPVphCA	Phase Voltage CA	unimplemented	uint16	V	V_SF	R	O	Phase Voltage CA
40080	Phase Voltage AN (PhVphA)	Fixed Block		10	8	1	PhVphA	Phase Voltage AN	supported	uint16	V	V_SF	R	M	Phase Voltage AN
40081	Phase Voltage BN (PhVphB)	Fixed Block		11	9	1	PhVphB	Phase Voltage BN	unimplemented	uint16	V	V_SF	R	O	Phase Voltage BN
40082	Phase Voltage CN (PhVphC)	Fixed Block		12	10	1	PhVphC	Phase Voltage CN	unimplemented	uint16	V	V_SF	R	O	Phase Voltage CN
40083	V_SF	Fixed Block		13	11	1	V_SF		-1	sunssf			R	M	
40084	Watts (W)	Fixed Block		14	12	1	W	Watts	supported	int16	W	W_SF	R	M	AC Power
40085	V_SF	Fixed Block		15	13	1	V_SF		-1	sunssf			R	M	
40086	Hz	Fixed Block		16	14	1	Hz	Hz	supported	uint16	Hz	Hz_SF	R	M	Line Frequency
40087	Hz_SF	Fixed Block		17	15	1	Hz_SF		-2	sunssf			R	M	
40088	VA	Fixed Block		18	16	1	VA	VA	supported	int16	VA	VA_SF	R	O	AC Apparent Power
40089	VA_SF	Fixed Block		19	17	1	VA_SF		-1	sunssf			R	O	
40090	Var	Fixed Block		20	18	1	Var	Var	supported	int16	var	Var_SF	R	O	AC Reactive Power
40091	Var_SF	Fixed Block		21	19	1	Var_SF		-1	sunssf			R	O	
40092	PF	Fixed Block		22	20	1	PF	PF	supported	int16	Pct	PF_SF	R	O	AC Power Factor
40093	PF_SF	Fixed Block		23	21	1	PF_SF		-3	sunssf			R	O	
40094	WattHours (WH)	Fixed Block		24	22	2	WH	WattHours	supported	acc32	Wh	WH_SF	R	M	AC Energy
40096	WH_SF	Fixed Block		26	24	1	WH_SF		0	sunssf			R	M	
40097	DC Amps (DCA)	Fixed Block		27	25	1	DCA	DC Amps	unimplemented	uint16	A	DCA_SF	R	O	DC Current
40098	DCA_SF	Fixed Block		28	26	1	DCA_SF		unimplemented	sunssf			R	O	
40099	DC Voltage (DCV)	Fixed Block		29	27	1	DCV	DC Voltage	unimplemented	uint16	V	DCV_SF	R	O	DC Voltage

40100	DCV_SF	Fixed Block		30	28	1	DCV_SF		unimplemented	sunssf			R	O	
40101	DC Watts (DCW)	Fixed Block		31	29	1	DCW	DC Watts	unimplemented	int16	W	DCW_SF	R	O	DC Power
40102	DCV_SF	Fixed Block		32	30	1	DCV_SF		unimplemented	sunssf			R	O	
40103	Temperature (TapCab)	Fixed Block		33	31	1	TapCab	Cabinet Temperature	supported	int16	C	Tap_SF	R	M	Cabinet Temperature
40104	Heat Sink Temperature (TapShk)	Fixed Block		34	32	1	TapShk	Heat Sink Temperature	unimplemented	int16	C	Tap_SF	R	O	Heat Sink Temperature
40105	Transformer Temperature (TapTrns)	Fixed Block		35	33	1	TapTrns	Transformer Temperature	unimplemented	int16	C	Tap_SF	R	O	Transformer Temperature
40106	Other Temperature (TapOt)	Fixed Block		36	34	1	TapOt	Other Temperature	unimplemented	int16	C	Tap_SF	R	O	Other Temperature
40107	Tap_SF	Fixed Block		37	35	1	Tap_SF		-1	sunssf			R	M	
40108	Operating State (St)	Fixed Block		38	36	1	St	Operating State	supported	enum16			R	M	Enumerated value. Opera
40109	Vendor Operating State (StVnd)	Fixed Block		39	37	1	StVnd	Vendor Operating State	unimplemented	enum16			R	O	Vendor specific operatir
40110	Event1 (Evt1)	Fixed Block		40	38	2	Evt1	Event1	supported	bitfield32			R	M	Bitmask value. Event fie
40112	Event Bitfield 2 (Evt2)	Fixed Block		42	40	2	Evt2	Event Bitfield 2	unimplemented	bitfield32			R	M	Reserved for future use
40114	Vendor Event Bitfield 1 (EvtVnd1)	Fixed Block		44	42	2	EvtVnd1	Vendor Event Bitfield 1	unimplemented	bitfield32			R	O	Vendor defined events
40116	Vendor Event Bitfield 2 (EvtVnd2)	Fixed Block		46	44	2	EvtVnd2	Vendor Event Bitfield 2	unimplemented	bitfield32			R	O	Vendor defined events
40118	Vendor Event Bitfield 3 (EvtVnd3)	Fixed Block		48	46	2	EvtVnd3	Vendor Event Bitfield 3	unimplemented	bitfield32			R	O	Vendor defined events
40120	Vendor Event Bitfield 4 (EvtVnd4)	Fixed Block		50	48	2	EvtVnd4	Vendor Event Bitfield 4	unimplemented	bitfield32			R	O	Vendor defined events

enum16	St	OFF	Off	1	supported										Device is not operating
enum16	St	SLEEPING	Sleeping	2	supported										Device is sleeping / auto-shutdown
enum16	St	STARTING	Starting	3	supported										Device is starting up
enum16	St	MPPT	MPPT	4	supported										Device is auto tracking maxiaum power point
enum16	St	THROTTLED	Throttled	5	supported										Device is operating at reduced power output
enum16	St	SHUTTING_DOWN	Shutting down	6	supported										Device is shutting down
enum16	St	FAULT	Fault	7	supported										One or more faults exist
enum16	St	STANDBY	Standby	8	supported										Device is in standby mode
bitfield32	Evt1	GROUND_FAULT	Ground fault	0	supported										
bitfield32	Evt1	DC_OVER_VOLT	DC over voltage	1	supported										
bitfield32	Evt1	AC_DISCONNECT	AC disconnect open	2	supported										
bitfield32	Evt1	DC_DISCONNECT	DC disconnect open	3	supported										
bitfield32	Evt1	GRID_DISCONNECT	Grid disconnect	4	supported										
bitfield32	Evt1	CABINET_OPEN	Cabinet open	5	supported										
bitfield32	Evt1	MANUAL_SHUTDOWN	Manual shutdown	6	supported										
bitfield32	Evt1	OVER_TEMP	Over temperature	7	supported										
bitfield32	Evt1	OVER_FREQUENCY	Frequency above limit	8	supported										
bitfield32	Evt1	UNDER_FREQUENCY	Frequency under limit	9	supported										
bitfield32	Evt1	AC_OVER_VOLT	AC Voltage above limit	10	supported										
bitfield32	Evt1	AC_UNDER_VOLT	AC Voltage under limit	11	supported										
bitfield32	Evt1	BLOWN_STRING_FUSE	Blown String fuse on input	12	supported										
bitfield32	Evt1	UNDER_TEMP	Under temperature	13	supported										
bitfield32	Evt1	MEMORY_LOSS	Generic Memory or Communication error (Internal)	14	supported										
bitfield32	Evt1	HW_TEST_FAILURE	Hardware test failure	15	supported										

RS485 send:01 03 9C 88 00 05 2B B3

Will recv:01 03 0A 01 C2 01 C2 00 00 00 00 FF FE DE 66

A\_SF(sunssf) = 0xFFFF=-2; Amps(A)(uint16) = (0x01C2) \* 10^A\_SF = 450\*10^-2 = 4.5A

RS485 send:01 03 9C AC 00 01 6A 7B

Will recv:01 03 02 00 04 B9 87

Operating State(enum16) = 0x0004=4, means MPPT mode



RS485 send:01 03 9C AE 00 01 CB BB

Will recv:01 03 02 81 23 99 CD

Event1(bitfield32) = 0x8123=1000000100100011B,means exist

GROUND\_FAULT,OVER\_TEMP,AC\_OVER\_VOLT,MEMORY\_LOSS,HW\_TEST\_FAILURE at the same time.

## for single phase inverter monitoring using float values:

Address	Point	Field Type	Applicable Point	Address Offset	Block Offset	Size	Name	Label	Value	Type	Units	R/W	Mandatory #/O	Description
40122	ID	Header		0		1	ID	Inverter (Single Phase) FLOAT	111	uint16		R	M	Include this model for single inverter monitoring using float
40123	L	Header		1		1	L		60	uint16		R	M	Model Length
40124	Amps (A)	Fixed Block		2	0	2	A	Amps	supported	float32	A	R	M	AC Current
40126	Amps PhaseA (AphA)	Fixed Block		4	2	2	AphA	Amps PhaseA	supported	float32	A	R	M	Phase A Current
40128	Amps PhaseB (AphB)	Fixed Block		6	4	2	AphB	Amps PhaseB	unimplemented	float32	A	R	O	Phase B Current
40130	Amps PhaseC (AphC)	Fixed Block		8	6	2	AphC	Amps PhaseC	unimplemented	float32	A	R	O	Phase C Current
40132	Phase Voltage AB (PFVphAB)	Fixed Block		10	8	2	PFVphAB	Phase Voltage AB	unimplemented	float32	V	R	O	Phase Voltage AB
40134	Phase Voltage BC (PFVphBC)	Fixed Block		12	10	2	PFVphBC	Phase Voltage BC	unimplemented	float32	V	R	O	Phase Voltage BC
40136	Phase Voltage CA (PFVphCA)	Fixed Block		14	12	2	PFVphCA	Phase Voltage CA	unimplemented	float32	V	R	O	Phase Voltage CA
40138	Phase Voltage AN (PhVphA)	Fixed Block		16	14	2	PhVphA	Phase Voltage AN	supported	float32	V	R	M	Phase Voltage AN
40140	Phase Voltage EN (PhVphE)	Fixed Block		18	16	2	PhVphE	Phase Voltage EN	unimplemented	float32	V	R	O	Phase Voltage EN
40142	Phase Voltage CN (PhVphC)	Fixed Block		20	18	2	PhVphC	Phase Voltage CN	unimplemented	float32	V	R	O	Phase Voltage CN
40144	Watts (W)	Fixed Block		22	20	2	W	Watts	supported	float32	W	R	M	AC Power
40146	Hz	Fixed Block		24	22	2	Hz	Hz	supported	float32	Hz	R	M	Line Frequency
40148	VA	Fixed Block		26	24	2	VA	VA	supported	float32	VA	R	O	AC Apparent Power
40150	VAr	Fixed Block		28	26	2	VAr	VAr	supported	float32	var	R	O	AC Reactive Power
40152	PF	Fixed Block		30	28	2	PF	PF	supported	float32	Pct	R	O	AC Power Factor
40154	WattHours (WH)	Fixed Block		32	30	2	WH	WattHours	supported	float32	Wh	R	M	AC Energy
40156	DC Amps (DCA)	Fixed Block		34	32	2	DCA	DC Amps	unimplemented	float32	A	R	O	DC Current
40158	DC Voltage (DCV)	Fixed Block		36	34	2	DCV	DC Voltage	unimplemented	float32	V	R	O	DC Voltage
40160	DC Watts (DCW)	Fixed Block		38	36	2	DCW	DC Watts	unimplemented	float32	W	R	O	DC Power
40162	Cabinet Temperature (TspCab)	Fixed Block		40	38	2	TspCab	Cabinet Temperature	supported	float32	C	R	M	Cabinet Temperature

RS485 send:01 03 9C BC 00 02 2B BF

Will recv:01 03 04 40 90 51 EC D3 C3

Amps = IEEE754(0x409051EC) = 4.51,units A

# for three phase inverter monitoring table:

Address	Point	Field Type	Applicable Point	Address Offset	Block Offset	Size	Name	Label	Value	Type	Units	SF	R/W	Mandatory I/O	Description
40070	ID	Header		0	1	1	ID	Inverter (Single Phase)	103	uint16			R	M	Include this model for s
40071	L	Header		1	1	1	L		50	uint16			R	M	Inverter monitoring Model Length
40072	Amps (A)	Fixed Block		2	0	1	A	Amps	supported	uint16	A	A_SF	R	M	AC Current
40073	Amps PhaseA (AphA)	Fixed Block		3	1	1	AphA	Amps PhaseA	supported	uint16	A	A_SF	R	M	Phase A Current
40074	Amps PhaseB (AphB)	Fixed Block		4	2	1	AphB	Amps PhaseB	supported	uint16	A	A_SF	R	O	Phase B Current
40075	Amps PhaseC (AphC)	Fixed Block		5	3	1	AphC	Amps PhaseC	supported	uint16	A	A_SF	R	O	Phase C Current
40076	A_SF	Fixed Block		6	4	1	A_SF		-2	sunssf			R	M	
40077	Phase Voltage AB (PPVphAB)	Fixed Block		7	5	1	PPVphAB	Phase Voltage AB	supported	uint16	V	V_SF	R	O	Phase Voltage AB
40078	Phase Voltage BC (PPVphBC)	Fixed Block		8	6	1	PPVphBC	Phase Voltage BC	supported	uint16	V	V_SF	R	O	Phase Voltage BC
40079	Phase Voltage CA (PPVphCA)	Fixed Block		9	7	1	PPVphCA	Phase Voltage CA	supported	uint16	V	V_SF	R	O	Phase Voltage CA
40080	Phase Voltage AN (PhVphA)	Fixed Block		10	8	1	PhVphA	Phase Voltage AN	unimplemented	uint16	V	V_SF	R	M	Phase Voltage AN
40081	Phase Voltage BN (PhVphB)	Fixed Block		11	9	1	PhVphB	Phase Voltage BN	unimplemented	uint16	V	V_SF	R	O	Phase Voltage BN
40082	Phase Voltage CN (PhVphC)	Fixed Block		12	10	1	PhVphC	Phase Voltage CN	unimplemented	uint16	V	V_SF	R	O	Phase Voltage CN
40083	V_SF	Fixed Block		13	11	1	V_SF		-1	sunssf			R	M	
40084	Watts (W)	Fixed Block		14	12	1	W	Watts	supported	int16	W	W_SF	R	M	AC Power
40085	V_SF	Fixed Block		15	13	1	V_SF		-1	sunssf			R	M	
40086	Hz	Fixed Block		16	14	1	Hz	Hz	supported	uint10	Hz	Hz_SF	R	M	Line Frequency
40087	Hz_SF	Fixed Block		17	15	1	Hz_SF		-2	sunssf			R	M	
40088	VA	Fixed Block		18	16	1	VA	VA	supported	int16	VA	VA_SF	R	O	AC Apparent Power
40089	VA_SF	Fixed Block		19	17	1	VA_SF		-1	sunssf			R	O	
40090	Var	Fixed Block		20	18	1	Var	Var	supported	int16	var	Var_SF	R	O	AC Reactive Power
40091	Var_SF	Fixed Block		21	19	1	Var_SF		-1	sunssf			R	O	
40092	PF	Fixed Block		22	20	1	PF	PF	supported	int16	Pct	PF_SF	R	O	AC Power Factor
40093	PF_SF	Fixed Block		23	21	1	PF_SF		-3	sunssf			R	O	
40094	WattHours (WH)	Fixed Block		24	22	2	WH	WattHours	supported	acc32	Wh	WH_SF	R	M	AC Energy
40096	WH_SF	Fixed Block		26	24	1	WH_SF		0	sunssf			R	M	
40097	DC Amps (DCA)	Fixed Block		27	25	1	DCA	DC Amps	unimplemented	uint16	A	DCA_SF	R	O	DC Current
40098	DCA_SF	Fixed Block		28	26	1	DCA_SF		unimplemented	sunssf			R	O	
40099	DC Voltage (DCV)	Fixed Block		29	27	1	DCV	DC Voltage	unimplemented	uint10	V	DCV_SF	R	O	DC Voltage
40100	DCV_SF	Fixed Block		30	28	1	DCV_SF		unimplemented	sunssf			R	O	
40101	DC Watts (DCW)	Fixed Block		31	29	1	DCW	DC Watts	unimplemented	int16	W	DCW_SF	R	O	DC Power
40102	DCW_SF	Fixed Block		32	30	1	DCW_SF		unimplemented	sunssf			R	O	
40103	Cabinet Temperature (TapCab)	Fixed Block		33	31	1	TapCab	Cabinet Temperature	supported	int16	C	Tap_SF	R	M	Cabinet Temperature
40104	Heat Sink Temperature (TapShk)	Fixed Block		34	32	1	TapShk	Heat Sink Temperature	unimplemented	int16	C	Tap_SF	R	O	Heat Sink Temperature
40105	Transformer Temperature (TapTrns)	Fixed Block		35	33	1	TapTrns	Transformer Temperature	unimplemented	int16	C	Tap_SF	R	O	Transformer Temperature
40106	Other Temperature (TapOt)	Fixed Block		36	34	1	TapOt	Other Temperature	unimplemented	int16	C	Tap_SF	R	O	Other Temperature
40107	Tap_SF	Fixed Block		37	35	1	Tap_SF		-1	sunssf			R	M	
40108	Operating State (St)	Fixed Block		38	36	1	St	Operating State	supported	enum16			R	M	Enumerated value. Opera
40109	Vendor Operating State (StVnd)	Fixed Block		39	37	1	StVnd	Vendor Operating State	unimplemented	enum16			R	O	Vendor specific operatir
40110	Event1 (Evt1)	Fixed Block		40	38	2	Evt1	Event1	supported	bitfield32			R	M	Bitask value. Event fie
40112	Event Bitfield 2 (Evt2)	Fixed Block		42	40	2	Evt2	Event Bitfield 2	unimplemented	bitfield32			R	M	Reserved for future use
40114	Vendor Event Bitfield 1 (EvtVnd1)	Fixed Block		44	42	2	EvtVnd1	Vendor Event Bitfield 1	unimplemented	bitfield32			R	O	Vendor defined events
40116	Vendor Event Bitfield 2 (EvtVnd2)	Fixed Block		46	44	2	EvtVnd2	Vendor Event Bitfield 2	unimplemented	bitfield32			R	O	Vendor defined events
40118	Vendor Event Bitfield 3 (EvtVnd3)	Fixed Block		48	46	2	EvtVnd3	Vendor Event Bitfield 3	unimplemented	bitfield32			R	O	Vendor defined events
40120	Vendor Event Bitfield 4 (EvtVnd4)	Fixed Block		50	48	2	EvtVnd4	Vendor Event Bitfield 4	unimplemented	bitfield32			R	O	Vendor defined events
enum16	St						OFF	Off	1	supported					Device is not operating
enum16	St						SLEEPING	Sleeping	2	supported					Device is sleeping / auto-shutdown
enum16	St						STARTING	Starting	3	supported					Device is starting up
enum16	St						MPPT	MPPT	4	supported					Device is auto tracking maxium power point
enum16	St						THROTTLED	Throttled	5	supported					Device is operating at reduced power output
enum16	St						SHUTTING_DOWN	Shutting down	6	supported					Device is shutting down
enum16	St						FAULT	Fault	7	supported					One or more faults exist
enum16	St						STANDBY	Standby	8	supported					Device is in standby mode
bitfield32	Evt1						GROUND_FAULT	Ground fault	0	supported					
bitfield32	Evt1						DC_OVER_VOLT	DC over voltage	1	supported					
bitfield32	Evt1						AC_DISCONNECT	AC disconnect open	2	supported					
bitfield32	Evt1						DC_DISCONNECT	DC disconnect open	3	supported					
bitfield32	Evt1						GRID_DISCONNECT	Grid disconnect	4	supported					
bitfield32	Evt1						CABINET_OPEN	Cabinet open	5	supported					
bitfield32	Evt1						MANUAL_SHUTDOWN	Manual shutdown	6	supported					
bitfield32	Evt1						OVER_TEMP	Over temperature	7	supported					
bitfield32	Evt1						OVER_FREQUENCY	Frequency above limit	8	supported					
bitfield32	Evt1						UNDER_FREQUENCY	Frequency under limit	9	supported					
bitfield32	Evt1						AC_OVER_VOLT	AC Voltage above limit	10	supported					
bitfield32	Evt1						AC_UNDER_VOLT	AC Voltage under limit	11	supported					
bitfield32	Evt1						BLOWN_STRING_FUSE	Blown String fuse on input	12	supported					
bitfield32	Evt1						UNDER_TEMP	Under temperature	13	supported					
bitfield32	Evt1						MEMORY_LOSS	Generic Memory or Communication error (internal)	14	supported					
bitfield32	Evt1						HW_TEST_FAILURE	Hardware test failure	15	supported					

RS485 send:01 03 9C 88 00 05 2B B3

Will rcv:01 03 0A 05 49 01 C2 01 C3 01 C4 FF FE 88 84

A\_SF(sunssf) = 0xFFFE=-2;

Amps(A)(uint16) = (0x0549) \* 10^A\_SF = 1353\*10^-2 = 13.53A

Amps PhaseA = (0x01C2) \* 10^A\_SF = 450\*10^-2 = 4.5A

Amps PhaseB = (0x01C3) \* 10^A\_SF = 451\*10^-2 = 4.51A

Amps PhaseC = (0x01C4) \* 10^A\_SF = 452\*10^-2 = 4.52A

RS485 send:01 03 9C AC 00 01 6A 7B

Will recv:01 03 02 00 04 B9 87

Operating State(enum16) = 0x0004=4, means MPPT mode

RS485 send:01 03 9C AE 00 01 CB BB

Will recv:01 03 02 81 23 99 CD

Event1(bitfield32) = 0x8123=1000000100100011B, means exist

GROUND\_FAULT, OVER\_TEMP, AC\_OVER\_VOLT, MEMORY\_LOSS, HW\_TEST\_FAILURE at the same time.

## for three phase inverter monitoring using float values:

Address	Point	Field Type	Applicable Point	Address Offset	Block Offset	Size	Name	Label	Value	Type	Units	R/W	Mandatory N/O	Description
40122	ID	Header		0	1	1	ID	Inverter (Three Phase)	113	uint16		R	M	
40123	L	Header		1	1	1	L	FLOAT	60	uint16		R	M	Include this model for three phase inverter monitoring using float Model Length
40124	Amper (A)	Fixed Block		2	0	2	A	Amper	supported	float32	A	R	M	AC Current
40126	Amper PhaseA (AphA)	Fixed Block		4	2	2	AphA	Amper PhaseA	supported	float32	A	R	M	Phase A Current
40128	Amper PhaseB (AphB)	Fixed Block		6	4	2	AphB	Amper PhaseB	supported	float32	A	R	O	Phase B Current
40130	Amper PhaseC (AphC)	Fixed Block		8	6	2	AphC	Amper PhaseC	supported	float32	A	R	O	Phase C Current
40132	Phase Voltage AB (FFVphAB)	Fixed Block		10	8	2	FFVphAB	Phase Voltage AB	supported	float32	V	R	O	Phase Voltage AB
40134	Phase Voltage BC (FFVphBC)	Fixed Block		12	10	2	FFVphBC	Phase Voltage BC	supported	float32	V	R	O	Phase Voltage BC
40136	Phase Voltage CA (FFVphCA)	Fixed Block		14	12	2	FFVphCA	Phase Voltage CA	supported	float32	V	R	O	Phase Voltage CA
40138	Phase Voltage AN (PhVphA)	Fixed Block		16	14	2	PhVphA	Phase Voltage AN	unimplemented	float32	V	R	M	Phase Voltage AN
40140	Phase Voltage EN (PhVphE)	Fixed Block		18	16	2	PhVphE	Phase Voltage EN	unimplemented	float32	V	R	O	Phase Voltage EN
40142	Phase Voltage CN (PhVphC)	Fixed Block		20	18	2	PhVphC	Phase Voltage CN	unimplemented	float32	V	R	O	Phase Voltage CN
40144	Watts (W)	Fixed Block		22	20	2	W	Watts	supported	float32	W	R	M	AC Power
40146	Hz	Fixed Block		24	22	2	Hz	Hz	supported	float32	Hz	R	M	Line Frequency
40148	VA	Fixed Block		26	24	2	VA	VA	supported	float32	VA	R	O	AC Apparent Power
40150	Var	Fixed Block		28	26	2	Var	Var	supported	float32	var	R	O	AC Reactive Power
40152	PF	Fixed Block		30	28	2	PF	PF	supported	float32	Pct	R	O	AC Power Factor
40154	WattHours (WH)	Fixed Block		32	30	2	WH	WattHours	supported	float32	Wh	R	M	AC Energy
40156	DC Amper (DCA)	Fixed Block		34	32	2	DCA	DC Amper	unimplemented	float32	A	R	O	DC Current
40158	DC Voltage (DCV)	Fixed Block		36	34	2	DCV	DC Voltage	unimplemented	float32	V	R	O	DC Voltage
40160	DC Watts (DCW)	Fixed Block		38	36	2	DCW	DC Watts	unimplemented	float32	W	R	O	DC Power
40162	Cabinet Temperature (TapCab)	Fixed Block		40	38	2	TapCab	Cabinet Temperature	supported	float32	C	R	M	Cabinet Temperature

RS485 send:01 03 9C BC 00 02 2B BF

Will recv:01 03 04 41 58 7A E1 8C F4

Amper = IEEE754(0x41587AE1) = 13.53, units A

## Immediate Inverter Controls :

Address	Point	Index	Subvalue	Value	R/W	Conformance Notes
40184	ID			123		Immediate Inverter Controls
40185	L			24		Model Length
40186	Conn_WinTms			unimplemented	RW	Time window for connect/disconnect.
40187	Conn_RvrtTms			unimplemented	RW	Timeout period for connect/disconnect.
40188	Conn			supported	RW	Enumerated valued. Connection control.
			DISCONNECT	supported		
			CONNECT	supported		
40189	VMaxLinPct			supported	RW	Set power output to specified level.
40190	VMaxLinPct_WinTms			unimplemented	RW	Time window for power limit change.
40191	VMaxLinPct_RvrtTms			unimplemented	RW	Timeout period for power limit.
40192	VMaxLinPct_RapTms			unimplemented	RW	Ramp time for moving from current setpoint to new setpoint.
40193	VMaxLim_Ena			supported	RW	Enumerated valued. Throttle enable/disable control.
			DISABLED	supported		
			ENABLED	supported		
40194	OutPFSet			unimplemented	RW	Set power factor to specific value - cosine of angle.
40195	OutPFSet_WinTms			unimplemented	RW	Time window for power factor change.
40196	OutPFSet_RvrtTms			unimplemented	RW	Timeout period for power factor.
40197	OutPFSet_RapTms			unimplemented	RW	Ramp time for moving from current setpoint to new setpoint.
40198	OutPFSet_Ena			unimplemented	RW	Enumerated valued. Fixed power factor enable/disable control.
			DISABLED	unimplemented		
			ENABLED	unimplemented		
40207	VMaxLinPct_SF			-1	R	Scale factor for power output percent.
40208	OutPFSet_SF			-1	R	Scale factor for power factor.
40209	VArPct_SF			-1	R	Scale factor for reactive power percent.

Turn on inverter:

RS485 send:01 10 9C FC 00 01 02 00 01 2F A5

Will recv:01 10 9C FC 00 01 EF A9

Shut down inverter:

RS485 send:01 10 9C FC 00 01 02 00 00 EE 65

Will recv:01 10 9C FC 00 01 EF A9

## DC Data (float) :

Address	Point	Index	Subvalue	Value	Type	R/W	Conformance Notes
40212	ID			114			
40213	L			48			
40214	DC Voltage (DCV1)			supported	float32	R	
40216	DC Voltage (DCV2)			supported	float32	R	
40218	DC Voltage (DCV3)			Depends on model	float32	R	
40220	DC Voltage (DCV4)			Depends on model	float32	R	
40222	DC Voltage (DCV5)			Depends on model	float32	R	
40224	DC Voltage (DCV6)			Depends on model	float32	R	
40226	DC Voltage (DCV7)			Depends on model	float32	R	
40228	DC Voltage (DCV8)			Depends on model	float32	R	
40230	DC Amps (DCA1)			supported	float32	R	
40232	DC Amps (DCA2)			supported	float32	R	
40234	DC Amps (DCA3)			Depends on model	float32	R	
40236	DC Amps (DCA4)			Depends on model	float32	R	
40238	DC Amps (DCA5)			Depends on model	float32	R	
40240	DC Amps (DCA6)			Depends on model	float32	R	
40242	DC Amps (DCA7)			Depends on model	float32	R	
40244	DC Amps (DCA8)			Depends on model	float32	R	
40246	DC Watt (DCW1)			supported	float32	R	
40248	DC Watt (DCW2)			supported	float32	R	
40250	DC Watt (DCW3)			Depends on model	float32	R	
40252	DC Watt (DCW4)			Depends on model	float32	R	
40254	DC Watt (DCW5)			Depends on model	float32	R	
40256	DC Watt (DCW6)			Depends on model	float32	R	
40258	DC Watt (DCW7)			Depends on model	float32	R	
40260	DC Watt (DCW8)			Depends on model	float32	R	

RS485 send:01 03 9D 36 00 02 0B A9

Will recv:01 03 04 42 F6 CC CD 9A EC

DC Watt(DCW1)= IEEE754(0x42F6CCCD) = 123.4,units W

DC Watt(DCW1) = IEEE754(0x42F6CCCD) = 123.4,units W