



APsystems Microinverter User Manual

APsystems DS3 series DS3-L and DS3 Microinverters (For APAC)



ALTENERGY POWER SYSTEM Inc.
global.apsystems.com

APsystems Shanghai:
Rm.B305 No.188, Zhangyang Road, Pudong, Shanghai
200120,P.R.C
Tel: 021-3392-8205 EMAIL: info.apac@APsystems.com

© All Rights Reserved

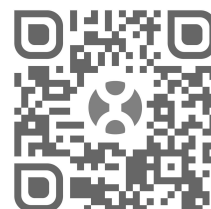

Please scan this QR code to
have access to our APPs and
Products information

Table of Contents

1. Important Safety Instructions.....	2
1.1 Safety Instructions.....	2
1.2 Radio Interference Statement.....	3
1.3 Symbols replace words on the equipment, on a display, or in manuals.....	4
2. APsystems Microinverter System Introduction.....	5
3. APsystems Microinverter DS3 series Introduction.....	7
4. APsystems Microinverter System Installation.....	8
4.1 Additional accessories supplied by APsystems.....	8
4.2 Other required accessories not supplied by APsystems.....	8
4.3 Installation Procedures.....	9
4.3.1 Step 1 - Verify that grid voltage is matching with microinverter rating.....	9
4.3.2 Step 2 - Y3 AC Bus Cable distribution.....	9
4.3.3 Step 3 - Attach the APsystems Microinverters to the Racking.....	9
4.3.4 Step 4 - Ground the system.....	10
4.3.5 Step 5 - Connect the APsystems microinverter to AC bus cable.....	10
4.3.6 Step 6 - Install a Bus Cable End Cap at the end of AC bus cable.....	11
4.3.7 Step 7 - Connect APsystems Microinverters to the PV Modules.....	12
4.3.8 Step 8 - Complete the APsystems installation map.....	13
4.3.9 Step 9 - Warning Notice.....	13
5. APsystems microinverter system operating instructions.....	14
6. Troubleshooting.....	15
6.1 Status Indications and Error Reporting.....	15
6.1.1 Start up LED.....	15
6.1.2 Operation LED.....	15
6.1.3 GFDI Error.....	15
6.2 ECU_APP.....	15
6.3 Installer EMA (web portal or EMA Manager APP).....	15
6.4 Trouble Shooting Guide.....	15
6.5 APsystems Technical Support.....	16
6.6 Maintenance.....	16
7. Replace a microinverter.....	17
8. Technical Data.....	18
8.1 DS3 series Microinverter Datasheet.....	19
9. DS3 series - Wiring Diagram.....	20
9.1 Sample Wiring Diagram - Single Phase.....	20

1. Important Safety Instructions

This manual contains important instructions to follow during installation and maintenance of the APsystems Photovoltaic Grid-connected Microinverter. To reduce the risk of electrical shock and ensure a safe installation and operation of the APsystems Microinverter, the following symbols appear throughout this document to indicate dangerous conditions and important safety instructions.

Specifications are subject to change without notice. Please ensure you are using the most recent update found at <https://global.apsystems.com/resources/library-landing/>

WARNING

This indicates a situation where failure to follow instructions may cause a serious hardware failure or personnel danger if not applied appropriately. Use extreme caution when performing this task.

NOTICE

This indicates information that is important for optimized microinverter operation. Follow these instructions closely.

1.1 Safety Instructions

- ✓ Only qualified professionals should install and/or replace APsystems Microinverters.
- ✓ Perform all electrical installations in accordance with local electrical codes.
- ✓ Before installing or using the APsystems Microinverter, please read all instructions and cautionary markings in the technical documents and on the APsystems Microinverter system and the solar array.
- ✓ **Do NOT** disconnect the PV module from the APsystems Microinverter without first disconnecting the AC power.
- ✓ Be aware that the body of the APsystems Microinverter is the heat sink and can reach a temperature of 80°C. To reduce risk of burns, do not touch the body of the Microinverter.
- ✓ **Do NOT** attempt to repair the APsystems Microinverter. If the microinverter is suspected to be faulty, please contact your local APsystems Technical Support to start troubleshooting and obtain a RMA (Return Merchandise Authorization) number to start the replacement process if needed. Damaging or opening the APsystems Microinverter will void the warranty.
- ✓ Caution!
When connecting a microinverter, it is recommended to first connect the AC Bus cable to the ground then connect the AC connector to ensure proper earthing of the microinverter, then do the DC connections. When disconnecting a microinverter disconnect the AC by opening the branch circuit breaker first but maintain the protective earthing conductor in the branch circuit breaker connected to the microinverter, then disconnect the DC inputs.
- ✓ Please install AC breakers on the AC side of the inverter.

1. Important Safety Instructions

1.2 Radio Interference Statement

EMC Compliance: The APsystems Microinverter can radiate radio frequency energy. If not installed and used in accordance with the instructions, it may cause harmful interference to radio communication.

APsystems Microinverter complies with EMC regulations, which are designed to provide reasonable protection against harmful interference in a residential installation.

Nonetheless, if the Microinverter does cause harmful interference to radio or television reception, you are encouraged to try to correct the interferences by one of more of the following measures:

- A) Reorient or relocate the receiving antenna
- B) Increase the separation between the Microinverter and the receiver
- C) Connect the Microinverter into an outlet on a circuit different from that to which the receiver is connected

If none of the recommendations suggested above bring significant improvement in terms of interferences, please contact your local APsystems Technical Support.

1. Important Safety Instructions

1.3 Symbols replace words on the equipment, on a display, or in manuals



Trademark.



Caution, risk of electric shock.



Caution, hot surface.



Symbol for the marking of electrical and electronics devices according to Directive 2002/96/EC. Indicates that the device, accessories and the packaging must not be disposed as unsorted municipal waste and must be collected separately at the end of the usage. Please follow Local Ordinances or Regulations for disposal or contact an authorized representative of the manufacturer for information concerning the decommissioning of equipment.



CE mark is attached to the solar inverter to verify that the unit follows the provisions of the European Low Voltage and EMC Directives.



Refer to the operating instructions.

Qualified personnel

Person adequately advised or supervised by an electrically skilled person to enable him or her to perceive risks and to avoid hazards which electricity can create. For the purpose of the safety information of this manual, a "qualified person" is someone who is familiar with requirements for safety, electrical system and EMC and is authorized to energize, ground, and tag equipment, systems, and circuits in accordance with established safety procedures. The inverter and photovoltaic system may only be commissioned and operated by qualified personnel.

2. APsystems Microinverter System Introduction

The APsystems Microinverter is used in utility-interactive grid-tied applications, comprised of three key elements:

- APsystems Microinverter
- APsystems Energy Communication Unit (ECU)
- APsystems Energy Monitor and Analysis (EMA) web-based monitoring and analysis system

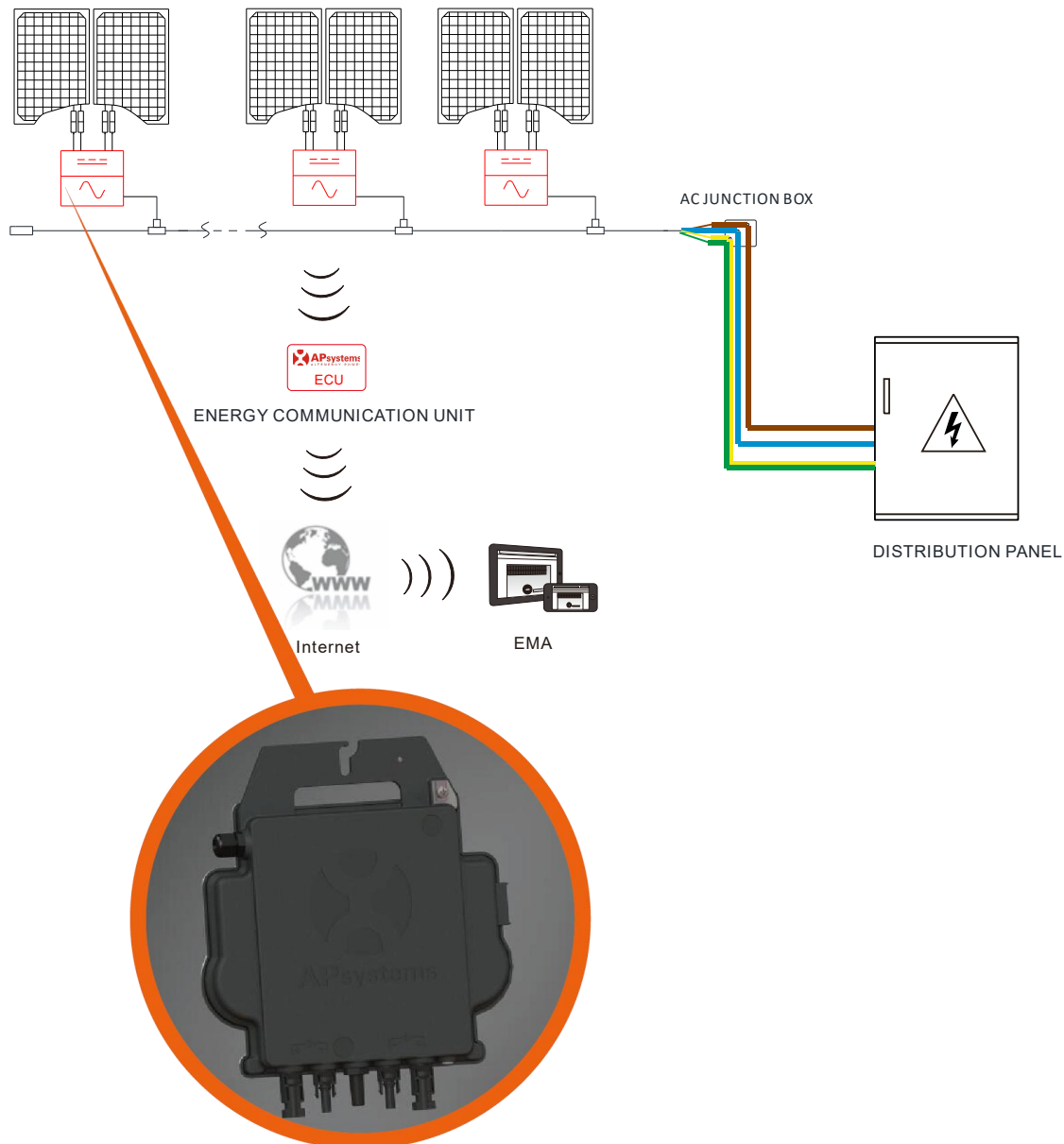

Figure 1

2. APsystems Microinverter System Introduction

This integrated system improves safety; maximizes solar energy harvest; increases system reliability, and simplifies solar system design, installation, maintenance, and management.

Safety with APsystems Microinverters

In a typical string inverter installation, PV modules are connected in series. The voltage adds-up to reach high voltage value (from 600Vdc up to 1000Vdc) at the end of the PV string. This extreme high DC voltage brings a risk of electrical shocks or electrical arcs which could cause fire.

When using an APsystems microinverter, PV modules are connected in parallel. Voltage at the back of each PV module never exceeds PV modules Voc, which is lower than 60Vdc for most of PV modules used with APsystems microinverters. This low voltage is considered “safe to touch” by fire departments and negates the risk of electrical shock, electrical arcs and fire hazards.

APsystems Microinverters maximize PV energy production

Each PV module has individual Maximum Peak Power Tracking (MPPT) control, which ensures that the maximum power is produced to the utility grid regardless of the performance of the other PV modules in the array. When PV modules in the array are affected by shade, dust, different orientation, or any situation in which one module underperforms compared with the other units, the APsystems Microinverter ensures top performance from the array by maximizing the performance of each module individually within the array.

More reliable than centralized or string inverters

The distributed APsystems Microinverter system ensures that no single point of system failure exists across the PV system. APsystems Microinverters are designed to operate at full power at ambient outdoor temperatures of up to 65 deg C (or 149 F). The inverter case is designed for outdoor installation and complies with the IP67 environmental enclosure rating.

Simple to install

APsystems Microinverters are compatible with most of 60 and 72 cell PV modules or 120 and 144 half-cut cells PV modules. (In order to confirm compatibility of PV module with APsystems microinverter, feel free to check our online “E-decider” module compatibility tool or contact your local APsystems Technical Support).

Installation requires a minimum number of accessories and microinverters offer a lot of versatility to the installer: microinverters can indeed be installed on different roofs with different orientation or with modules having different orientation.

In the same way, end-users can extend their system whenever they want with microinverters.

Smart system performance monitoring and analysis

The APsystems Energy Communication Unit (ECU) is installed by simply plugging it into any wall outlet and providing an Ethernet or Wi-Fi connection to a broadband router or modem. After installing and setting the ECU (see ECU Instruction Manual), the full network of APsystems Microinverters automatically reports to the APsystems Energy Monitor and Analysis (EMA) web server.

3. APsystems Microinverter DS3 series Introduction

APsystems 3rd generation of dual microinverters are reaching unprecedented power outputs of 730VA or 880VA to adapt to today's larger power module. With 2 independent MPPT, encrypted Zigbee signals, the DS3-L and DS3 benefit from an entirely new architecture and are fully backwards compatible with the QS1 and YC600 microinverters.

The innovative and compact design make the product lighter while maximizing power production. The components are encapsulated with silicone to reduce stress on the electronics, facilitate thermal dissipation, enhance waterproof properties, and ensure maximum reliability of the system via rigorous testing methods including accelerated life testing. A 24/7 energy access through Apps or web based portal facilitate remote diagnosis and maintenance.

The DS3 series is interactive with power grids through a feature referred to as RPC (Reactive Power Control) to better manage photovoltaic power spikes in the grid. With a performance and an efficiency of 97%, a unique integration with 20% less components, APsystems DS3-L and DS3 are a game changer to residential and commercial PV.

Key Product Feature:

- One microinverter connects to two PV modules
- Maximum output power reaching 730VA (DS3-L) or 880VA (DS3)
- Two input channels with independent MPPT
- Reactive Power Control
- Maximum reliability, IP67
- Encrypted Zigbee communication
- Safety protection relay integrated
- Single phase microinverter. Possible to install in a balanced 3-phase system

4. APsystems Microinverter System Installation

A PV system using APsystems Microinverters is simple to install. Each Microinverter easily mounts on the PV racking, directly beneath the PV module(s). Low voltage DC wires connect from the PV module directly to the Microinverter, eliminating the risk of high DC voltage. Installation MUST comply with local regulations and technical rules.

Special Statement: we advise installation of an RCD breaker only if required by the local electrical code.

WARNING

- ①. Perform all electrical installations in accordance with local electrical codes.
- ②. Be aware that only qualified professionals should install and/or replace APsystems Microinverters.
- ③. Before installing or using an APsystems Microinverter, please read all instructions and warnings in the technical documents and on the APsystems Microinverter system itself as well as on the PV array.
- ④. Be aware that installation of this equipment includes the risk of electric shock.
- ⑤. Do not touch any live parts in the system, including the PV array, when the system has been connected to the electrical grid.

NOTICE

Even if not required by local electrical code, we strongly recommend to install surge protection devices in the dedicated AC box.

4.1 Additional accessories supplied by APsystems

- AC Y3 Bus cable
- AC Y3 Bus Cable End Cap
- AC Y3 Bus Cable Y-CONN Cap
- AC Y3 Bus Cable Unlock Tool
- ECU
- AC connectors male/female

4.2 Other required accessories not supplied by APsystems

In addition to your PV array and its associated hardware, you may need the following items:

- An AC connection junction box
- Mounting hardware suitable for module racking
- Sockets and wrenches for mounting hardware

4. APsystems Microinverter System Installation

4.3 Installation Procedures

4.3.1 Step 1 - Verify that grid voltage matches microinverter rating

4.3.2 Step 2 - Y3 AC Bus Cable distribution

- Each connector drop of the AC Bus cable matches the position of the microinverter.
- One end of the AC bus cable is used to access the junction box into the power grid.
- Wire the conductors of the AC bus: L - BROWN ; N - BLUE; PE - YELLOW GREEN.

⚠ WARNING

Wiring color code can be different according to local regulations. Check all the wires of the installation before connecting to the AC bus to be sure they match. Improper cabling can irreparably damage the microinverters: such damage is not covered by the warranty.

⚠ WARNING

It is strictly prohibited to hand carry the microinverter by its AC cable.

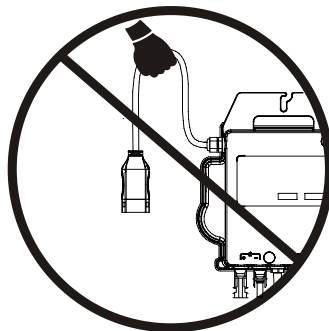

4.3.3 Step 3 - Attach the APsystems Microinverters to the Racking

- Mark the location of the microinverter on the rack, with respect to the PV module junction box or any other obstructions.
- Mount one microinverter at each of these locations using hardware recommended by your module racking vendor.

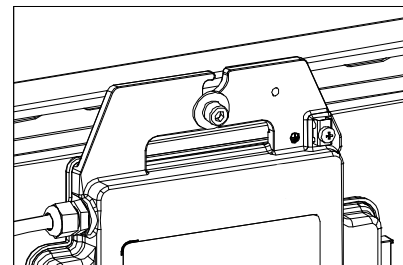
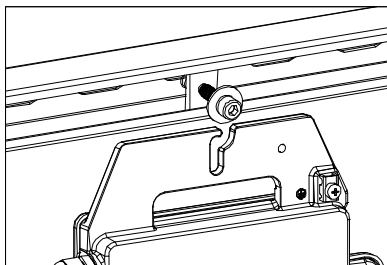
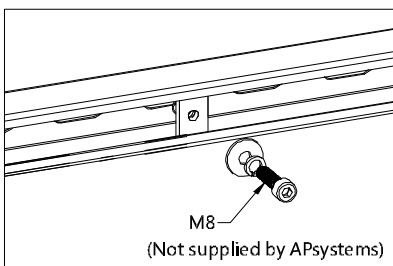

Figure 2

⚠ WARNING

Install the microinverters (including DC and AC connectors) under the PV modules to avoid direct exposure to rain, UV or other harmful weather events. Allow a minimum of 1.5 cm (3/4") below and above the casing of the microinverter to allow proper air flow. The racking must be properly grounded as per local electrical code.

4. APsystems Microinverter System Installation

4.3.4 Step 4 - Ground the system

Y3 AC Bus cable has an embedded PE wire: this might be sufficient to ensure proper grounding of the whole PV array. However, in areas with special grounding requirements, external grounding work may still be needed, using the grounding lug supplied with the Microinverter

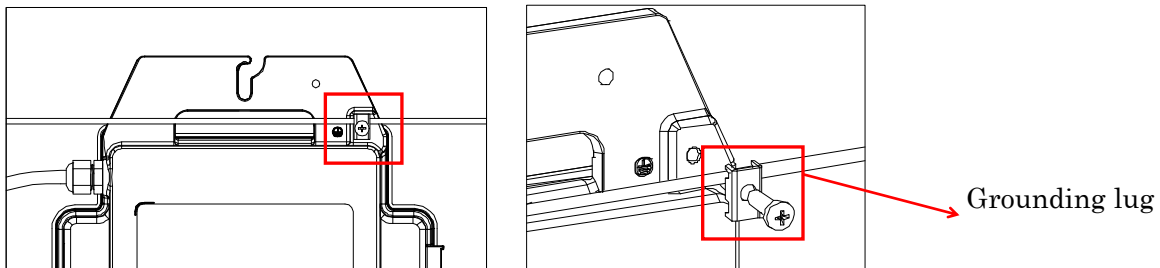

Figure 3

4.3.5 Step 5 - Connect the APsystems microinverter to AC bus cable

Insert the microinverter AC connector into the trunk cable connector. Make sure to hear the “click” as a proof of robust connection

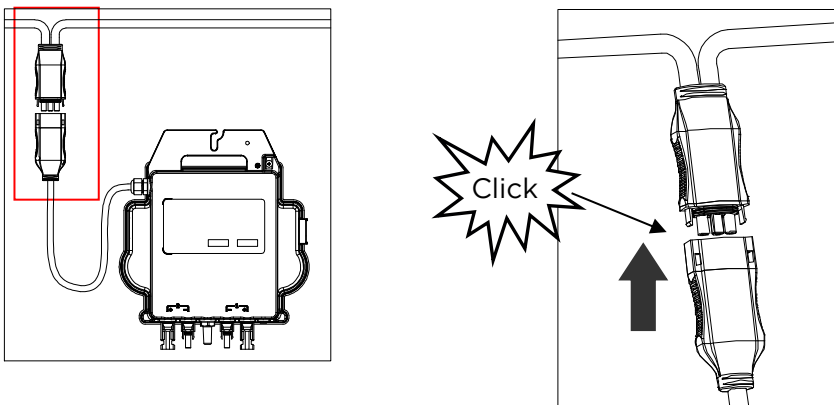

Figure 4

Best Practice: Use the AC Bus Cable Unlock Tool to disconnect the connectors.

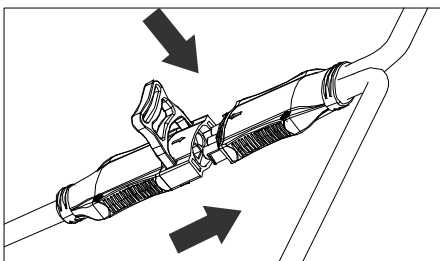

Figure 5

NOTICE

Check the microinverter technical data page 19 to confirm maximum allowable number of microinverters on each AC branch of the circuit.

4. APsystems Microinverter System Installation

AC connector interface as from left to right.

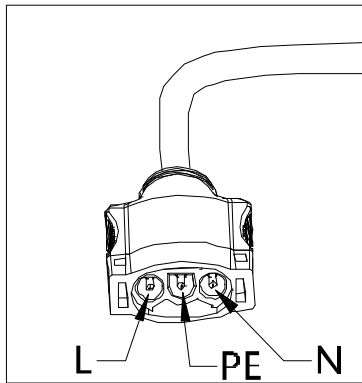

Figure 6

Cover any unused connectors with Bus Cable Y-CONN Cap to protect the unused connectors.

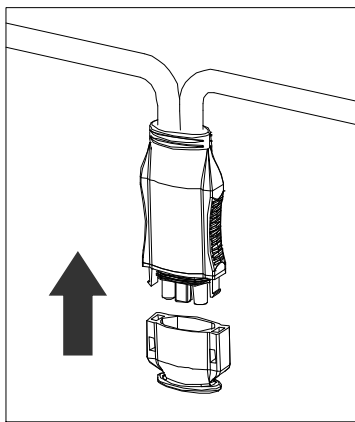
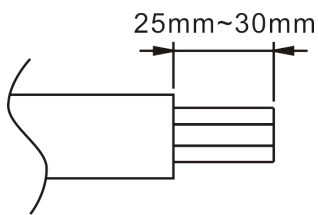

Figure 7

4.3.6 Step 6 - Install a Bus Cable End Cap at the end of AC bus cable

a. Strip cable jacket.



b. Insert the cable end into the seal.

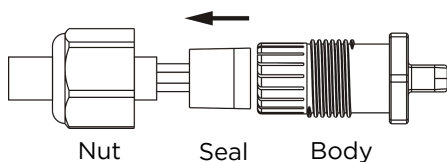

c. Insert the wires into the cable clamps.

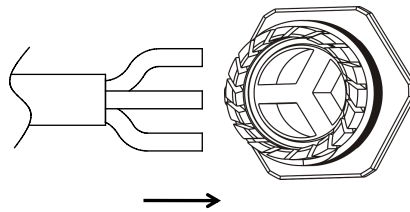

d. Rotate the nut with 3.3N·m until the latching mechanism meets the base.

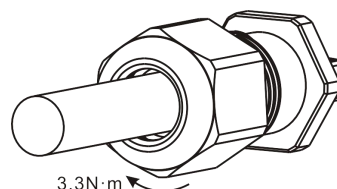

Figure 8

4. APsystems Microinverter System Installation

4.3.7 Step 7 - Connect APsystems Microinverters to the PV Modules

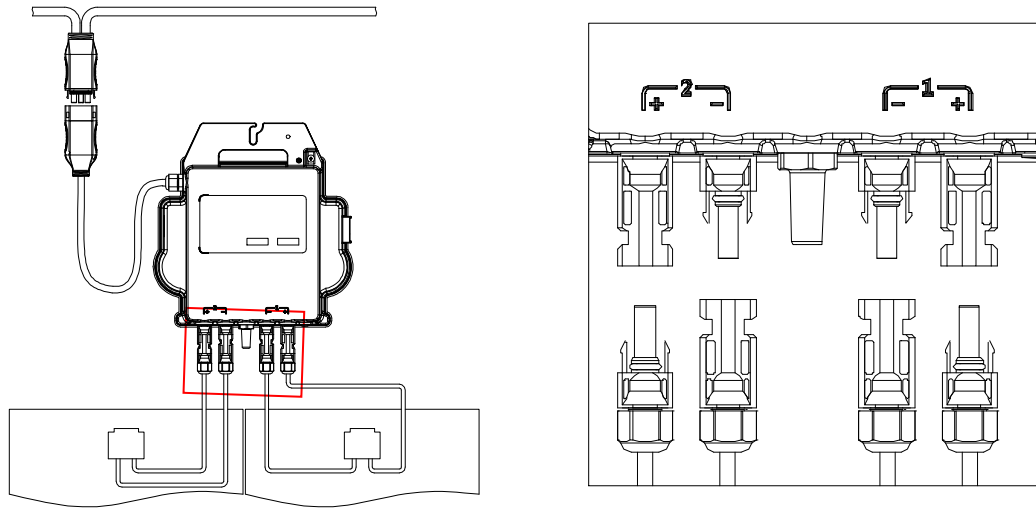

Figure 9

NOTICE

When plugging in the DC cables, the microinverter should immediately blink red one time and green ten times. This will happen as soon as the DC cables are plugged in and will show that the microinverter is functioning correctly. This entire check function will start and end within 10 seconds of plugging in the unit, so pay careful attention to these lights when connecting the DC cables.

WARNING

Double check to make sure all of the AC and DC wiring has been correctly installed. Ensure that none of the AC and/or DC wires are pinched or damaged. Make sure that all of the junction boxes are properly closed.

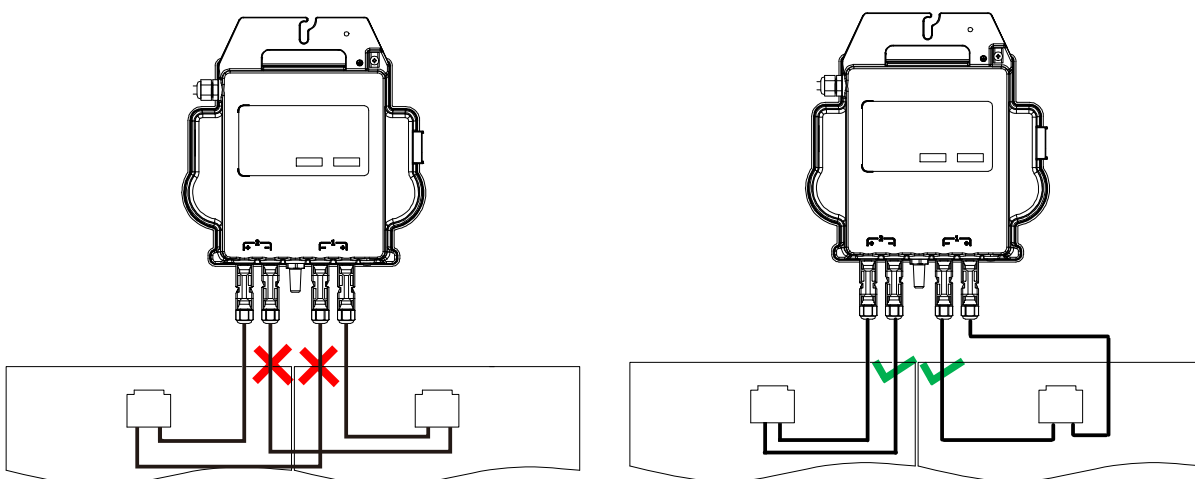

WARNING

Each PV panel must be carefully connected to the same channel. Make sure to not split positive and negative DC cables into two different input channels: microinverter will become damaged and warranty will not apply.

4. APsystems Microinverter System Installation

4.3.8 Step 8 - Complete the APsystems installation map

- Each APsystems Microinverter has 2 removable serial number labels.
- Complete the installation map by sticking the ID label of each microinverter in the right location.
- The second serial number label, could be stuck on the solar module frame, which could help later to confirm the position of the microinverter without dismantling the PV module

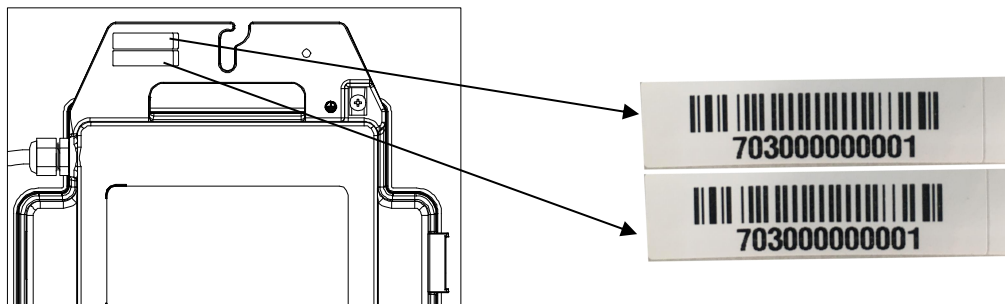

Figure 10

NOTICE

- The layout of the microinverters' serial number installation map is only suitable for a typical installation.
- Installation Map is available in the last page appendix of this manual.
- Use ECU_APP (available in the EMA Manager) to scan the serial numbers on the map when setting up the ECU (see ECU instruction manual for more info).

4.3.9 Step 9 - Warning Notice

A warning notice must be placed in such a way that anyone with access to live parts is warned in advance of the need to switch off these parts. It is imperative to verify that the power supply, measurement circuits (sense lines) and other parts are not isolated from the network when the interface protection switch is open.

As a minimum, warning labels shall be placed:

- On the switchboard (DNO panel and consumer unit) that has the PV generator connected to it;
- On all switchboards in between the consumer unit and the PV generator itself;
- On, or in the PV generator itself;
- At all points of isolation for the PV generator

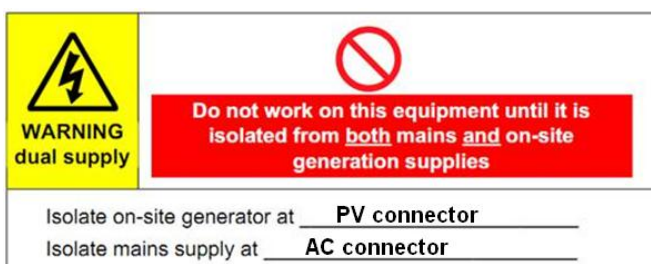

5. APsystems microinverter system operating instructions

To operate the APsystems microinverter PV system:

1. Turn ON the AC circuit breaker on each microinverter AC branch circuit.
2. Turn ON the main utility-grid AC circuit breaker. Your system will start producing power after approximately one minute of waiting time.
3. Microinverter data will be available in the EMA Manager APP or in the EMA web portal.

Alternatively, LED sequences could be an indicator of microinverters status (see section 6.1)



NOTICE

Once the ECU has been commissioned properly, the APsystems Microinverters will start to send performance data to the ECU. The time required for all of the Microinverters in the system to report to the ECU will vary depending on the number of Microinverters in the system.

6. Troubleshooting

Qualified personnel can use the following troubleshooting steps if the PV system does not operate correctly:

6.1 Status Indications and Error Reporting

Assuming they are easily accessible and visible, Operation LEDs can give a good indication of the microinverters status

6.1.1 Start up LED

One short red and ten short green blinks when DC power is first applied to the Microinverter indicates a successful Microinverter startup.

6.1.2 Operation LED

Flashing Slow Green (5 sec. gap) - Producing power and communicating with ECU

Flashing Slow Red (5 sec. gap) - Not producing power

Flashing Fast Green (2 sec. gap) - Not communicating with ECU over 60mins, but still producing power.

Flashing Fast Red (2 sec. gap) - Not communicating with ECU over 60mins and not producing power.

Steady Red - default, DC side ground fault protection, see 6.1.3

6.1.3 GFDI Error

A solid red LED indicates the Microinverter has detected a Ground Fault Detector Interrupter (GFDI) error in the PV system. Unless the GFDI error has been cleared, the LED will remain red and the ECU will keep reporting the fault. Please contact your local APsystems Technical Support.

6.2 ECU_APP

APsystems ECU_APP (available in the EMA Manager APP) is the recommended tool to do on-site troubleshooting. When connecting the ECU_APP to the ECU hotspot (please check ECU User Manual for more detailed information), installer can check every microinverter status (production, communication) but also Zigbee signal strength, grid profile and other insightful data helping the troubleshooting.

6.3 Installer EMA (web portal or EMA Manager APP)

Before going on site for troubleshooting, installer can also check all information remotely using his installer account, either on the web or using the EMA Manager APP (see EMA Manager APP User Manual for more detailed information). Having access to module data (DC, AC, voltages and currents) gives the first indication on potential issues.

6.4 Trouble Shooting Guide

Professional installers can also refer to our Troubleshooting Guide (<https://global.apsystems.com/resources/library-landing/>, section libraries) for more in depth guidelines on how to troubleshoot and fix PV installations powered by APsystems microinverters.

6. Troubleshooting

6.5 APsystems Technical Support

The APsystems local Technical Support team is available to support professional installers in becoming familiar with our products and to troubleshoot installations when needed.

WARNING

Do not attempt to repair APsystems Microinverters. Please contact your local APsystems Technical Support.

WARNING

- ①. Never disconnect the DC wire connectors under load. Ensure that no current is flowing in the DC wires prior to disconnecting.
- ②. Always disconnect AC power before disconnecting the PV module wires from the APsystems Microinverter.
- ③. The APsystems Microinverter is powered by PV module DC power. AFTER disconnecting the DC power, when reconnecting the PV modules to the Microinverter, be sure to watch for the quick red light followed by ten short green LED flashes.

6.6 Maintenance

APsystems microinverters do not require any specific regular maintenance.

7. Replace a microinverter

Follow the procedure to replace a failed APsystems Microinverter

- A. Disconnect the APsystems Microinverter from the PV Module, in the order shown below:
 1. Disconnect the AC by turning off the branch circuit breaker.
 2. Disconnect the inverter AC connector from the AC Bus.
 3. Disconnect the PV module DC wire connectors from the microinverter.
 4. Remove the Microinverter from the PV array racking.

- B. Install a replacement Microinverter to the rack. Remember to observe the flashing green LED light as soon as the new Microinverter is plugged into the DC cables.

- C. Connect the AC cable of the replacement Microinverter to the AC bus.

- D. Close the branch circuit breaker, and verify proper operation of the replacement Microinverter.

- E. Update the microinverter in the EMA Manager through the "Replace" function and update the system's map with new serial number labels.

8. Technical Data



WARNING

- ①. Be sure to verify that the voltage and current specifications of your PV module are compatible with the range allowed on APsystems Microinverter. Please check the microinverter datasheet.
- ②. DC operating voltage range of the PV module must be within allowable input voltage range of the APsystems Microinverter.
- ③. The maximum open circuit voltage of the PV module must not exceed the specified maximum input voltage of the APsystems.

8.1 DS3 series Microinverter Datasheet

Model	DS3-L	DS3
Input Data (DC)		
Recommended PV Module Power (STC) Range	255Wp-550Wp+	300Wp-660Wp+
Peak Power Tracking Voltage	25V-55V	32V-55V
Operating Voltage Range	16V-60V	26V-60V
Maximum Input Voltage	60V	
Maximum Input Current	18A x 2	20A x 2
Output Data (AC)		
Maximum Continuous Output Power	730VA	880VA
Nominal Output Voltage/Range*	230V/184-253V	
Nominal Output Current	3.2A	3.8A
Nominal Output Frequency/ Range*	50Hz/48Hz-51Hz	
Power Factor(Default/Adjustable)	0.99/0.8 leading...0.8 lagging	
Maximum Units per 20A Branch**	6	5
Efficiency		
Peak Efficiency	97%	
CEC Efficiency	96.5%	
Nominal MPPT Efficiency	99.5%	
Night Power Consumption	20mW	
Mechanical Data		
Operating Ambient Temperature Range	-40 °C to +65 °C	
Storage Temperature Range	-40 °C to +85 °C	
Dimensions (W x H x D)	262mm X 218mm X 41.2mm	
Weight	2.6kg	
AC Bus Cable	2.5mm ²	
DC Connector Type	Stäubli MC4 PV-ADBP4-S2&ADSP4-S2	
Cooling	Natural Convection - No Fans	
Enclosure Environmental Rating	IP67	
Features		
Communication (Inverter To ECU)	Encrypted ZigBee	
Isolation Design	High Frequency Transformers, Galvanically Isolated	
Energy Management	Energy Management Analysis (EMA) system	
Warranty***	10 Years Standard ; 20 Years Optional	
Compliances		
Safety, EMC & Grid Compliances	EN 62109-1; EN 62109-2; EN 61000-6-1; EN 61000-6-3; UNE217002,UNE206007-1,RD647,RD1699,RD413; CEI 0-21; VDE0126-1-1,VFR2019,UTE C15-712-1,ERDF-NOI-RES_13E; EN 50549-1; VDE-AR-N 4105	

*Nominal voltage/frequency range can be extended beyond nominal if required by the utility.

**Limits may vary. Refer to local requirements to define the number of microinverters per branch in your area.

*** To be eligible for the warranty, APsystems microinverters need to be monitored via the EMA portal. Please refer to our warranty T&Cs available on global.apsystems.com.

© All Rights Reserved

Specifications subject to change without notice please ensure you are using the most recent update found at web : global.apsystems.com

9. DS3 series - Wiring Diagram

9.1 Sample Wiring Diagram - Single Phase

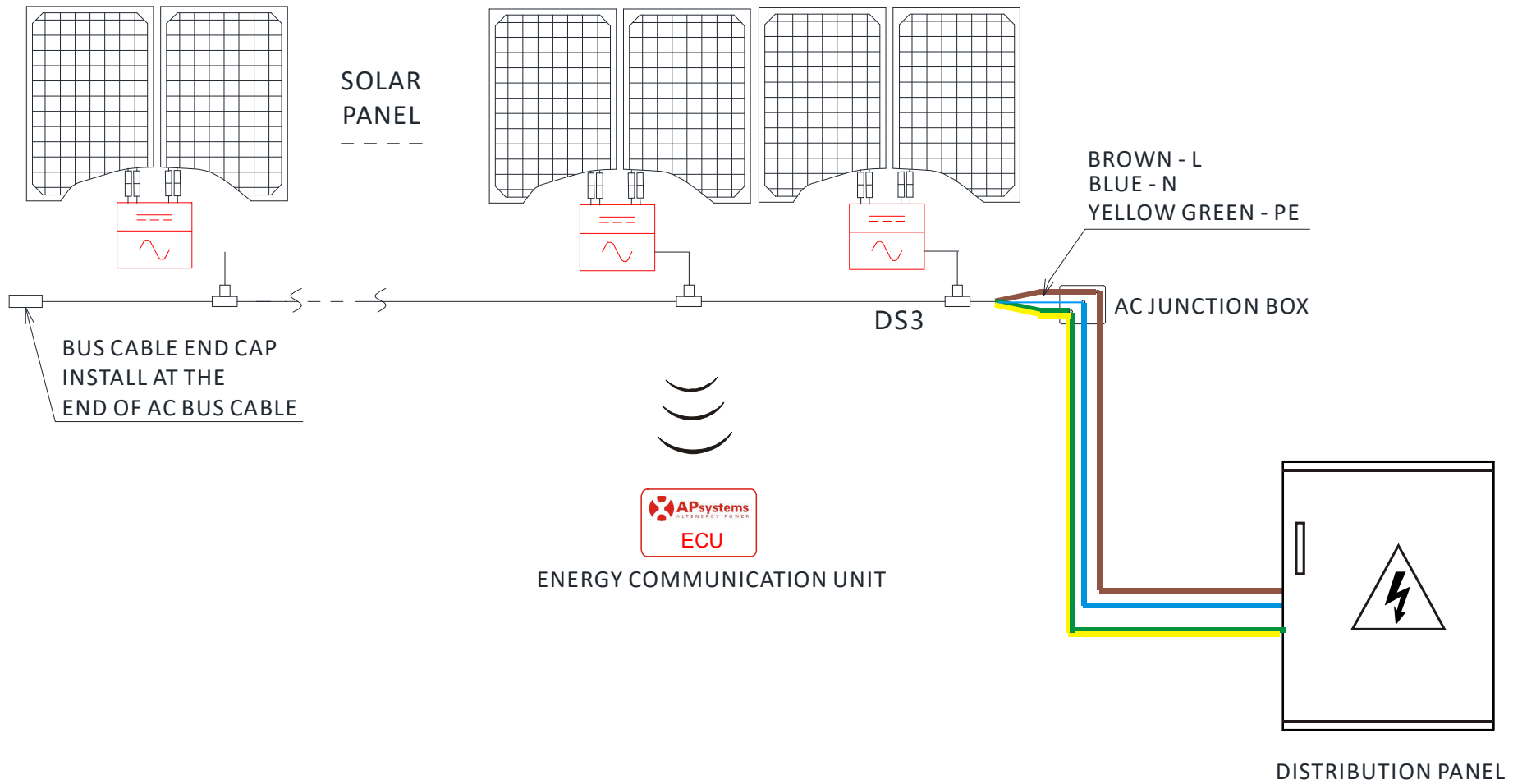



Figure 12

APsystems Microinverter & Energy Communication Unit Installation Map

The APsystems Installation Map is a diagram of the physical location of each microinverter in your PV installation. Each APsystems microinverter has two serial number labels. Peel the one label and affix it to the respective location on the APsystems installation map.
Installation Map Template

Installer:		PV module type:			Qty:		Sheet ___ of ___	
Owner:		Microinverter type:			Qty:			
	Column 1	Column 2	Column 3	Column 4	Column 5	Column 6	Column 7	
Row 1								
Row 2								
Row 3								
Row 4								
Row 5								
Row 6								
Row 7								
Row 8								
Row 9								
Row 10								