

Introduction of APsystems YC1000 Anti-backflow System solutions

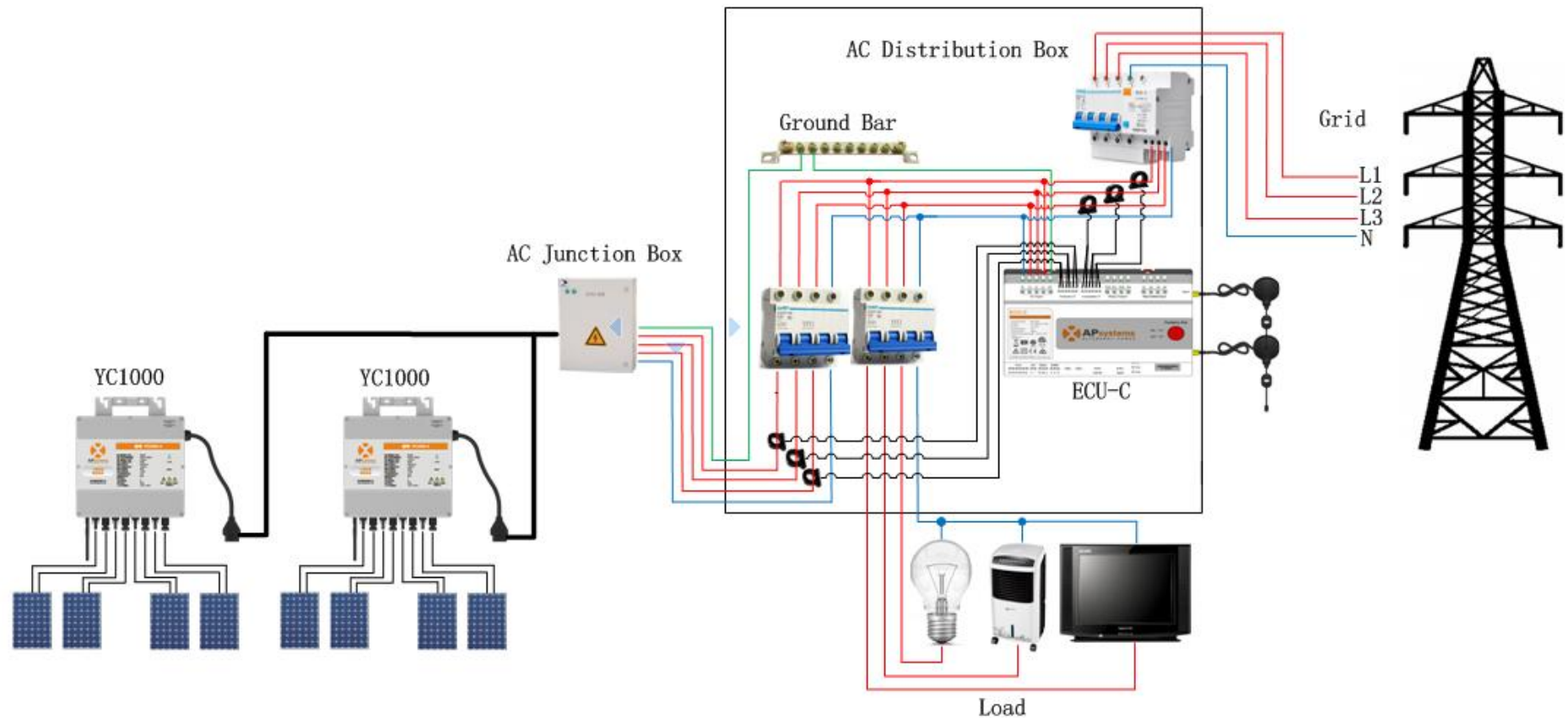

Figure1

APsystems YC1000 Anti-backflow System solutions schematic diagram, please refer to figure 1. By installing Current Transformer (CT) at the power generation side of PV system and the grid side, ECU-C could measure the generation&grid power and energy of each phase. To any phase, When the grid side current measured by the CT is negative, the electric current will flow back into the grid. Before the backflow occurs or the backflow power of any phase is greater than the power limit, ECU-C will shut all the inverters down through communication. According to the power calculation, under the condition of no backflow or backflow power of any phase smaller than the power limit, ECU-C will turn on inverters one by one as many as possible to guarantee the maximum power generation.

APsystems

Suite 502, 8 Help Street, Chatswood NSW 2067 Australia
61 (0)2 8034 6587 | APsystems.com

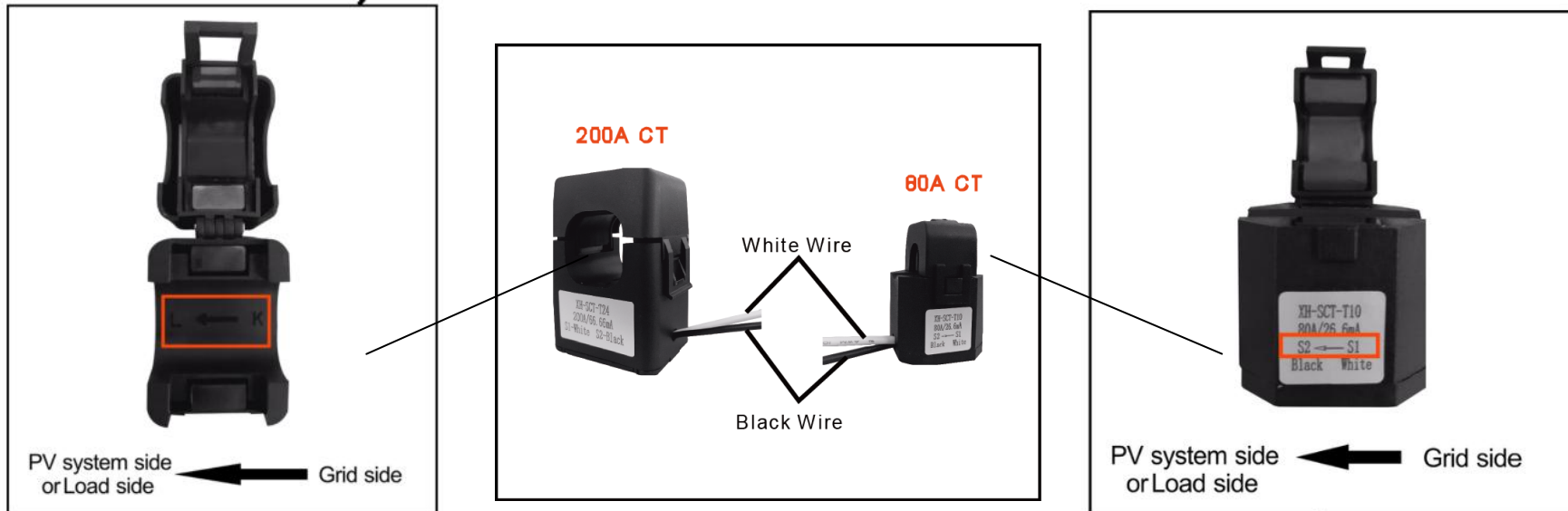
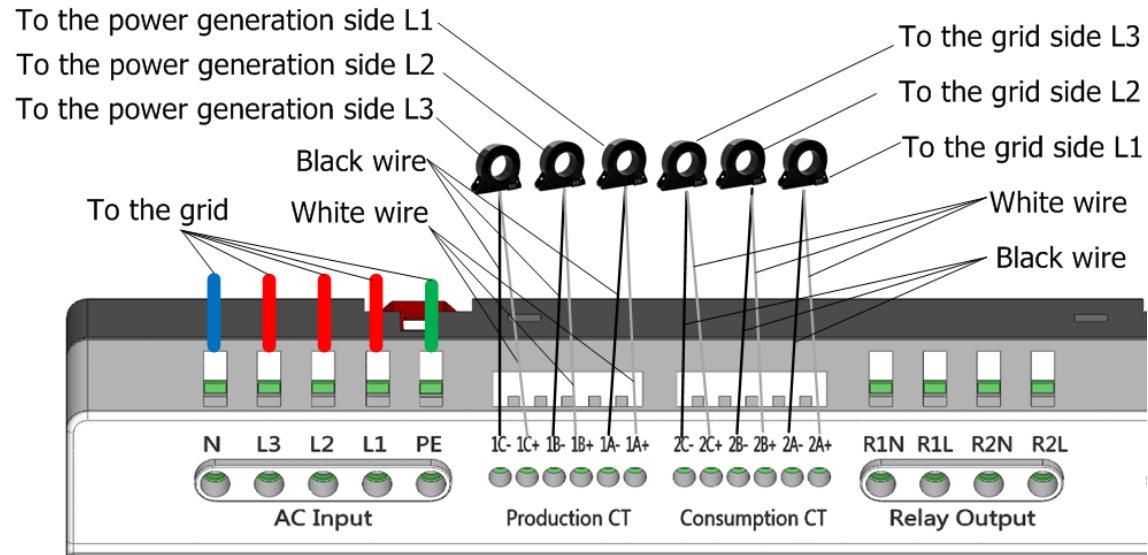
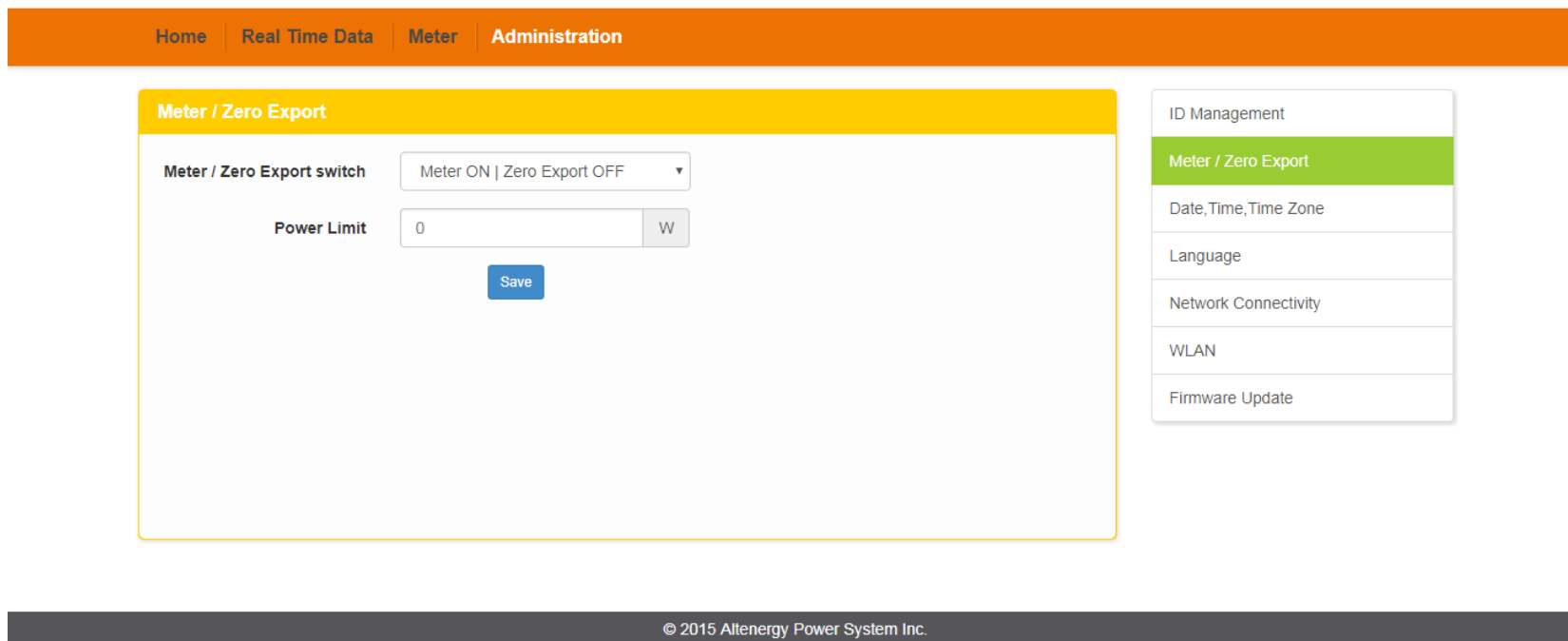

Figure2

ECU-C has requirements for the wiring and coil direction of Current Transformer, please refer to figure2. The AC input side L1、L2、L3、N,PE should be accessed to the grid. At the Production CT, the 3 current transformers should be accessed to the power generation side. At the Consumption CT, the 3 current transformers should be accessed to the grid side. These following points should be noted: the Current Transformer between A+ and A- must be accessed to the same grid phase with the AC input side L1; the Current Transformer between B+ and B- must be accessed to the same grid phase with the AC input side L2; the Current Transformer between C+ and C- must be accessed to the same grid phase with the AC input side L3.



Home | Real Time Data | Meter | Administration

Meter / Zero Export

Meter / Zero Export switch: Meter ON | Zero Export OFF

Power Limit: 0 W

Save

ID Management

Meter / Zero Export

Date, Time, Time Zone

Language

Network Connectivity

WLAN

Firmware Update

© 2015 Altenessy Power System Inc.

Figure 3

Anti-backflow function can be opened or closed in the ECU-C Local Network Interface like figure 3. In this interface you can also set power limit from 0 to a certain positive number. The power limit means that anti-backflow function works only when the backflow occurs and the backflow power of any phase is greater than the power limit.